



Microstrip Filter Design

Jia-Sheng Hong

Heriot-Watt University
Edinburgh, UK

J.Hong@hw.ac.uk

Outline



Introduction



Design considerations



Design examples



Summary

Introduction- Driving forces

Recent development of microstrip filters has been driven by applications -

- Wireless communications**
- Wireless sensor/radar systems**
-

Driven by technologies -

- High temperature superconducting**
- Micromachining**
- LTCC**
- Ferroelectric**
-

Introduction- Microstrip Filter Publications

Total 600+ in recent 10 years

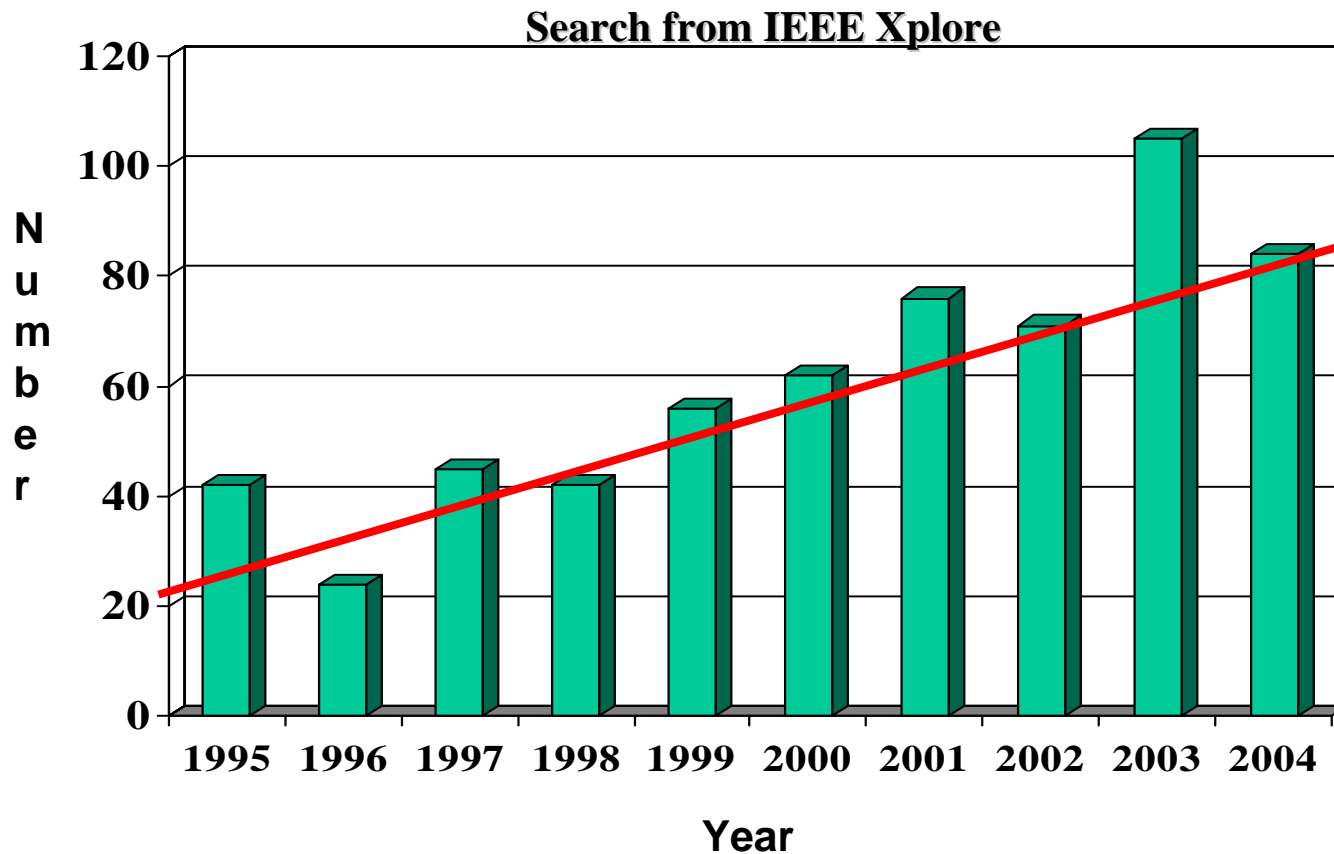

Design Considerations- Topologies

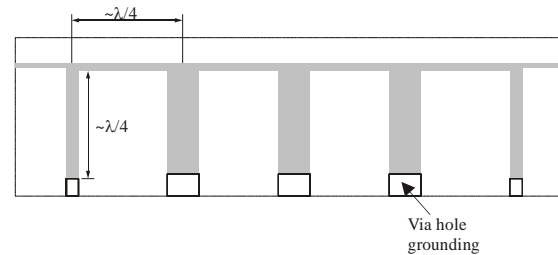
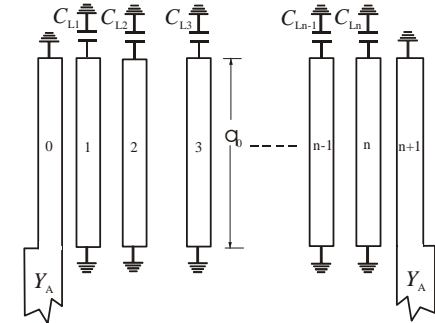
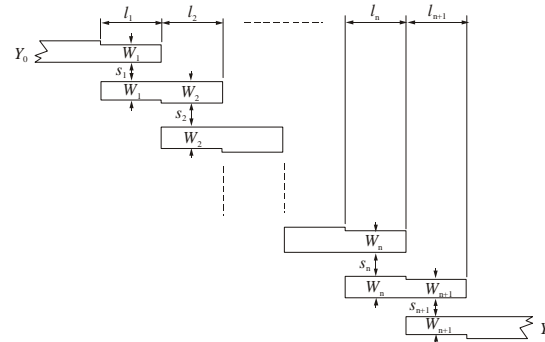
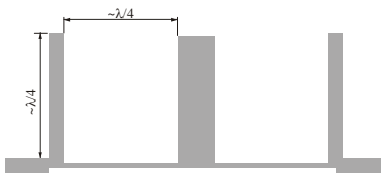
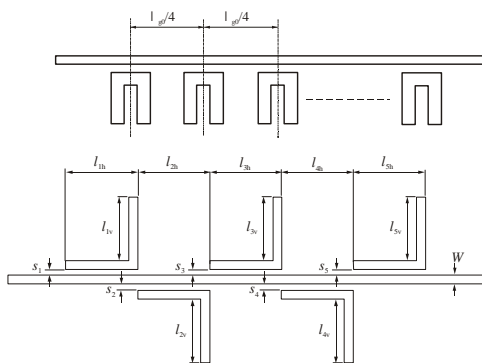
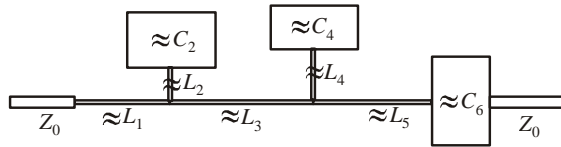
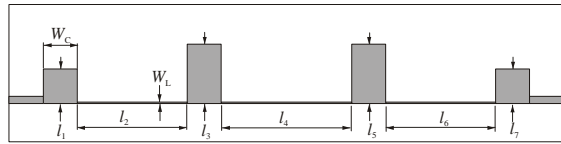

Design Considerations- Topologies

The choice of a topology depends on

- ✓ Characteristics of filters, such as chebyshev or elliptic
- ✓ Bandwidth
- ✓ Size
- ✓ Power handling

Design Considerations- Substrates

The choice of a substrate depends on

- ✓ Size
- ✓ Higher-order modes
- ✓ Surface wave effects
- ✓ Implementations – couplings, line/spacing tolerances, ...
- ✓ Dielectric loss
- ✓ Temperature stability
- ✓ Power handling – dielectric strength (breakdown), thermal conductivity

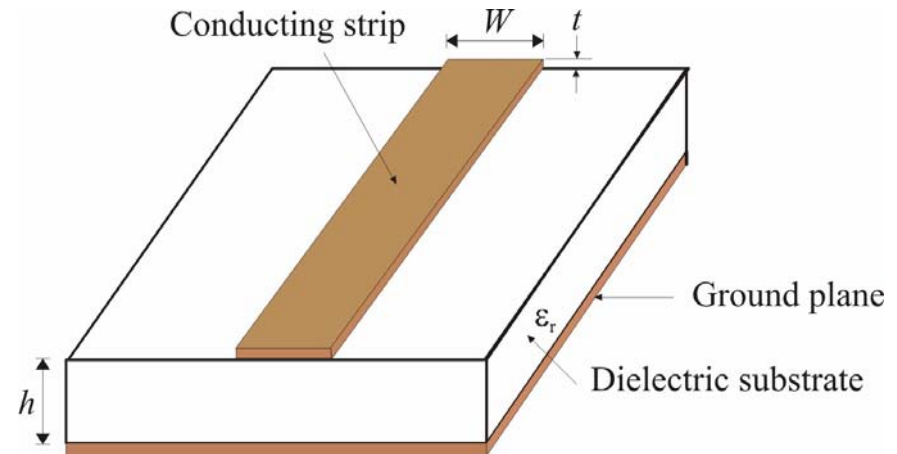

Design Considerations- Higher-order modes

- ✓ Keep operating frequencies below the cutoff frequency of the 1st higher-order mode,

$$f_c = \frac{c}{\sqrt{\epsilon_r}(2W + 0.8h)}$$

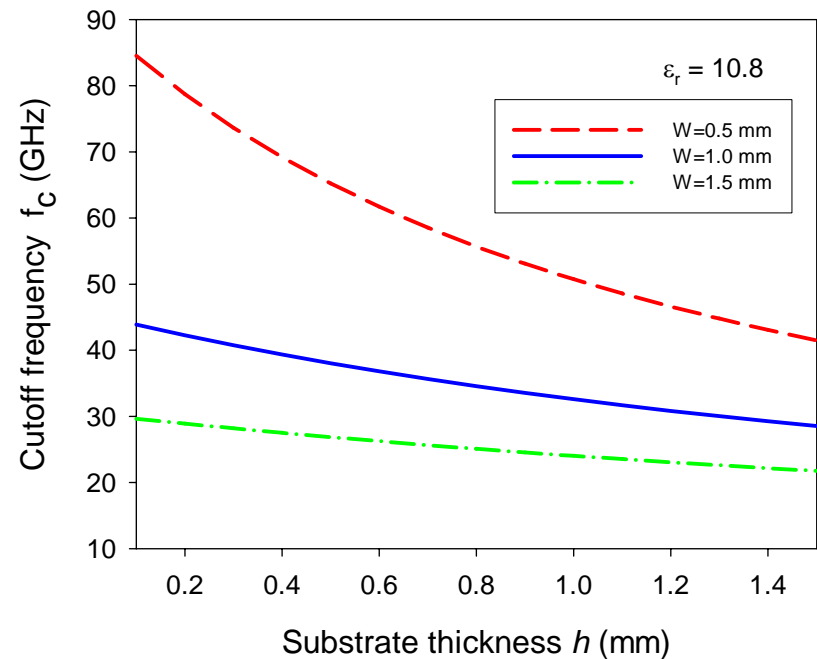
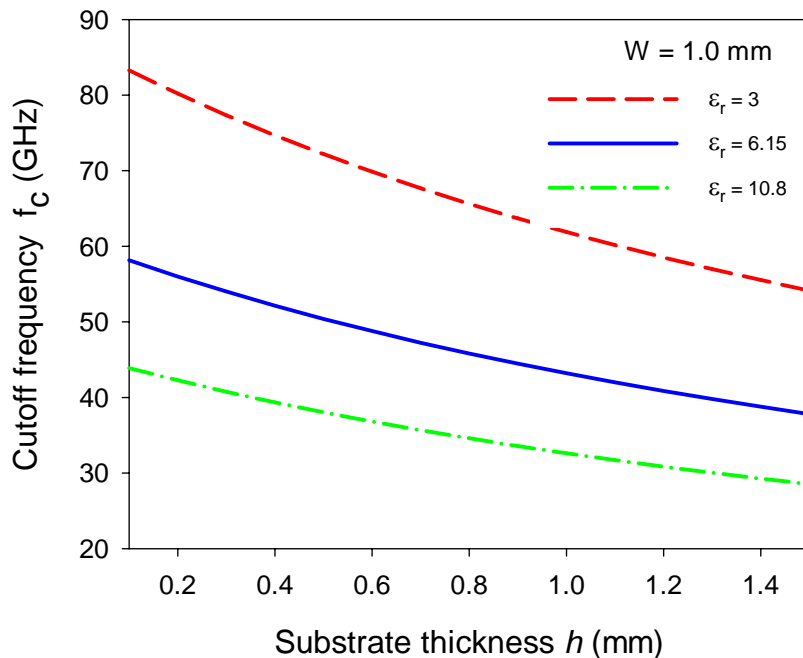

Design Considerations- Surface waves

- ✓ Keep operating frequencies below the threat frequency of the lowest surface wave mode,

$$f_s = \frac{c \tan^{-1} \epsilon_r}{\sqrt{2\pi h} \sqrt{\epsilon_r - 1}}$$

at which the surface mode couples strongly to the dominant mode of microstrip because the phase velocities of the two modes are close.

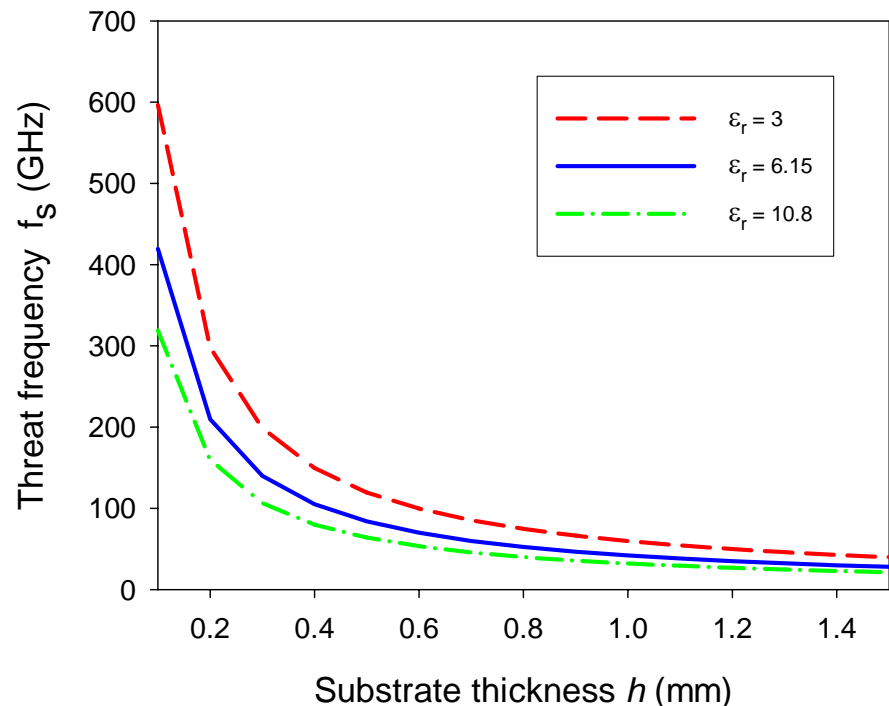

Design Considerations- Losses

There are three major losses in a microstrip resonator:

□ Conductor loss $Q_c \propto \pi \left(\frac{h}{\lambda} \right) \cdot \left(\frac{377\Omega}{R_s} \right)$

□ Dielectric loss $Q_d \propto \frac{1}{\tan \delta}$

□ Radiation loss

$$\frac{1}{Q_u} = \frac{1}{Q_c} + \frac{1}{Q_d} + \frac{1}{Q_r}$$

Design Considerations- Power handling

□ Peak power handling capability –

when the breakdown occurs in substrate

$$P_p \propto \frac{V_o^2}{2Z_c}$$

V_o is the maximum breakdown voltage of the substrate

Z_c is the characteristic impedance of the microstrip

**Narrower band filters result in higher electric field density,
leading to a lower peak power handling**

Design Considerations- Temperature effect

Temperature characteristic of a microstrip half-wavelength resonator on RT/Duroid substrate with $\epsilon_r = 10.2$, $h = 1.27$ mm

Copper CTE (coefficient of thermal expansion) = 17 ppm/°C
Substrate CTE = 24 ppm/°C
Substrate TCK (thermal coefficient of ϵ_r) = -425 ppm/°C

At 23 °C	$f_0 = 1929.8$ MHz	$\Delta f = 0$
At 73 °C for copper CTE only	$f_0 = 1928.1$ MHz	$\Delta f = -1.7$ MHz
At 73 °C for substrate thickness CTE only	$f_0 = 1929.9$ MHz	$\Delta f = 0.1$ MHz
At 73 °C for substrate TCK only	$f_0 = 1949.4$ MHz	$\Delta f = 19.6$ MHz
At 73 °C (consider all)	$f_0 = 1947.8$ MHz	$\Delta f = 18.0$ MHz

- ✓ **Frequency variation versus temperature is mainly due to dielectric constant change vs temperature**

Design Examples- Open-loop filters

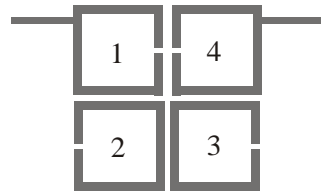

(a)

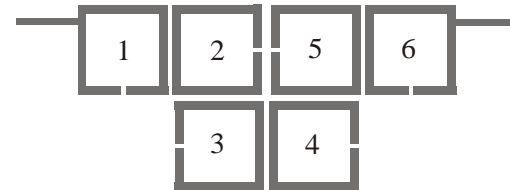

(b)

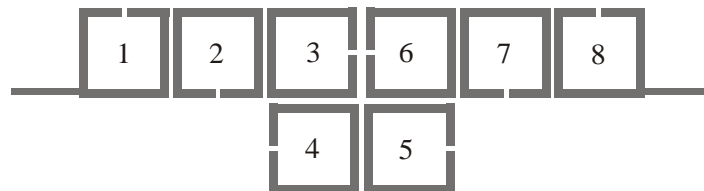

(c)

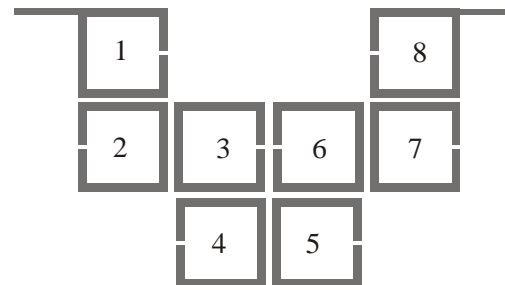

(d)

From: Jia-Sheng Hong and M.J.Lancaster, *Microstrip Filters for RF/Microwave Applications*,
John Wiley & Sons. Inc. New York, 2001

Design Examples- Open-loop filters

➤ Specifications:

Center frequency	985MHz
Fractional Bandwidth	10.359%
40dB-Rejection Bandwidth	125.5MHz
Passband Return loss	-20dB

➤ Design parameters for an 8-pole filter:

$$M_{1,2} = M_{7,8} = 0.08441$$

$$M_{2,3} = M_{6,7} = 0.06063$$

$$M_{3,4} = M_{5,6} = 0.05375$$

$$M_{4,5} = 0.0723$$

$$M_{3,6} = -0.01752$$

$$Q_{ei} = Q_{eo} = 9.92027$$

Design Examples- Open-loop filters

Realisation 1

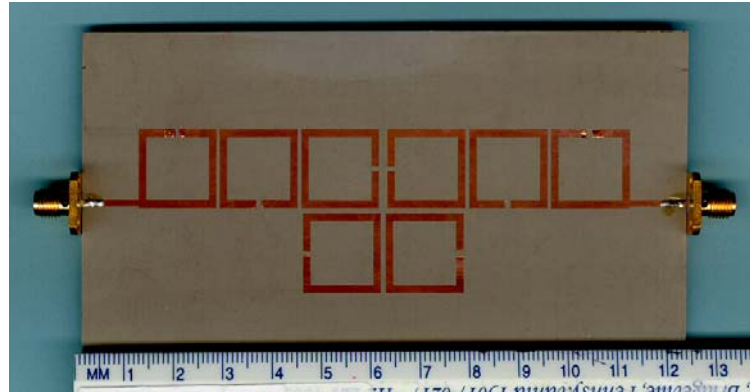

On RT/Duroid substrate with a relative dielectric constant of 10.8 and a thickness of 1.27mm. Each resonator has a size of 16 by 16 mm.

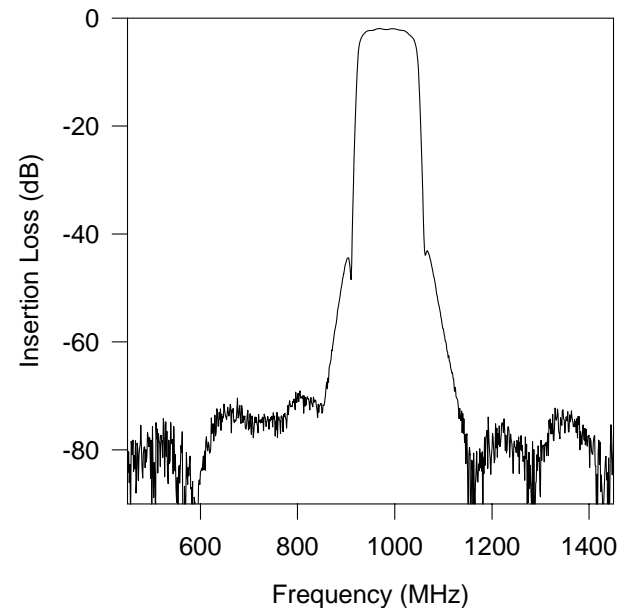
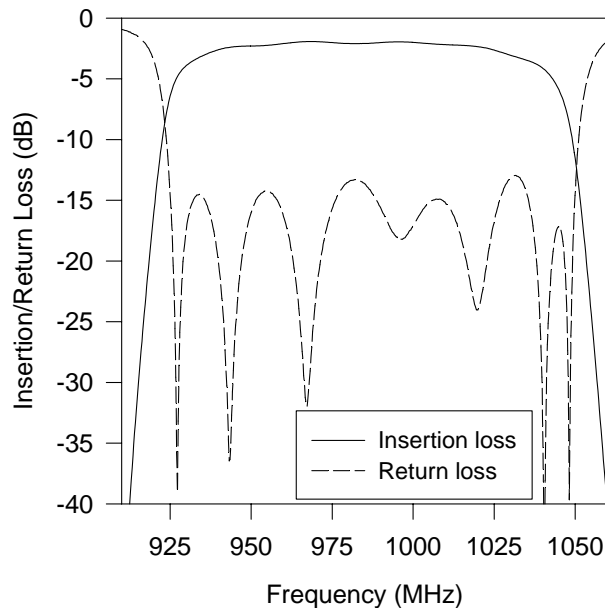

Design Examples- Open-loop filters

Realisation 2

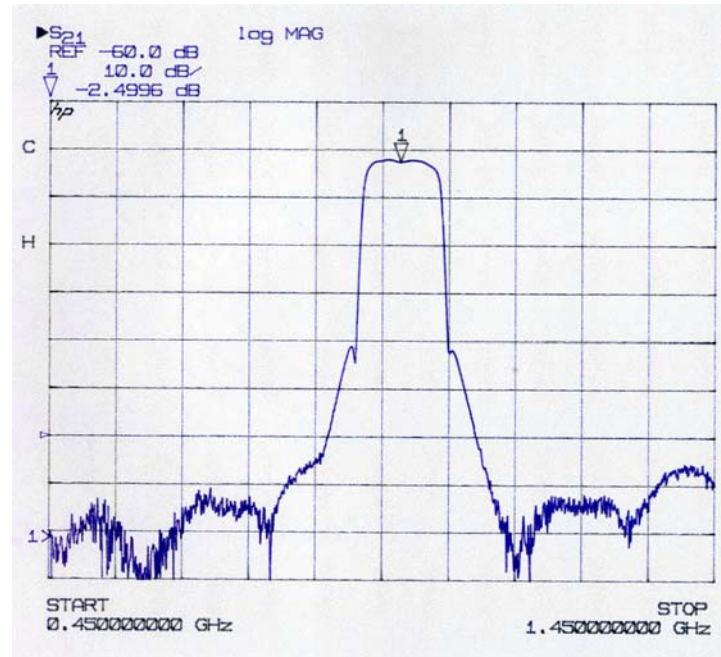
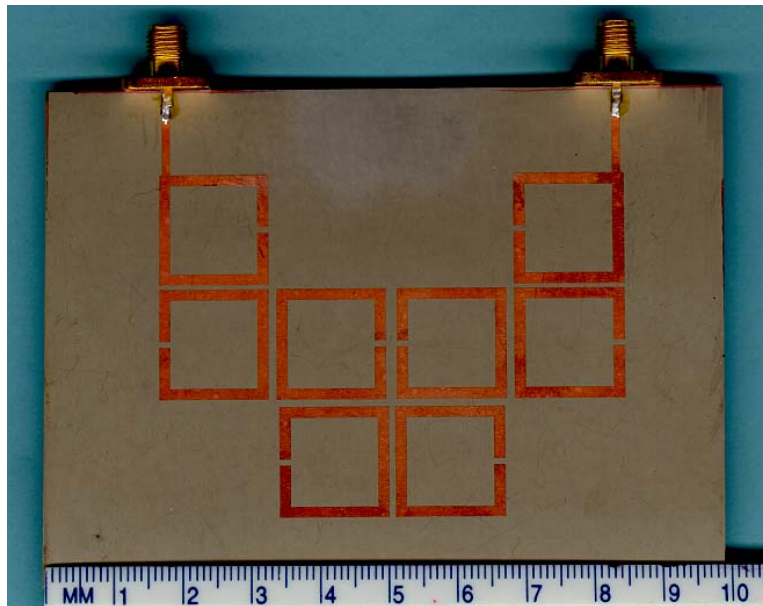

On RT/Duroid substrate with a relative dielectric constant of 10.8 and a thickness of 1.27mm

Design Examples- Trisection open-loop filters

Midband or centre frequency : 905MHz
Bandwidth of pass band : 40MHz
Return loss in the pass band : < -20dB
Rejection : > 20dB for frequencies ≥ 950 MHz

$$f_{01} = f_{03} = 899.471 \text{ MHz}$$

$$f_{02} = 914.713 \text{ MHz}$$

$$Q_{ei} = Q_{eo} = 15.7203$$

$$M_{12} = M_{23} = 0.04753$$

$$M_{13} = -0.02907$$

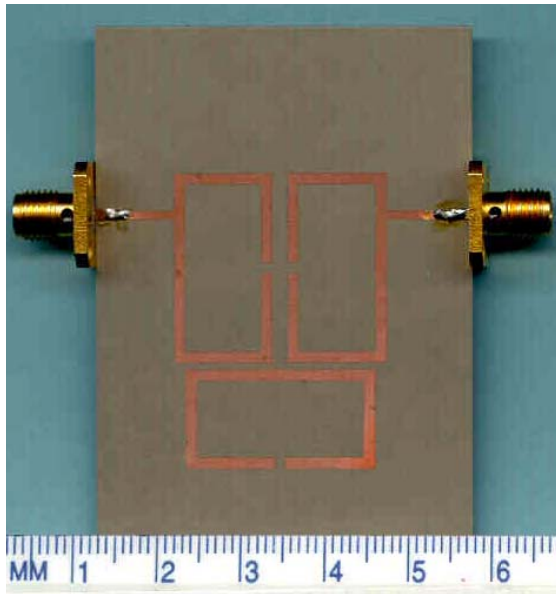

On RT/Duroid substrate with a relative dielectric constant of 10.8 and a thickness of 1.27mm

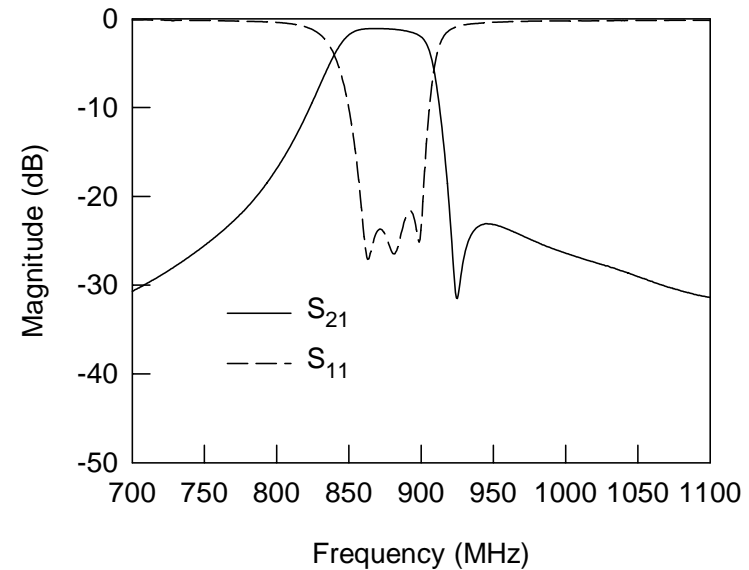

Measured response

Design Examples- Trisection open-loop filters

Midband or centre frequency : 910MHz
Bandwidth of pass band : 40MHz
Return loss in the pass band : < -20dB
Rejection : > 35dB for frequencies \leq 843MHz

$$f_{01} = f_{03} = 916.159 \text{ MHz}$$

$$f_{02} = 905.734 \text{ MHz}$$

$$Q_{ei} = Q_{eo} = 14.6698$$

$$M_{12} = M_{23} = 0.05641$$

$$M_{13} = 0.01915$$

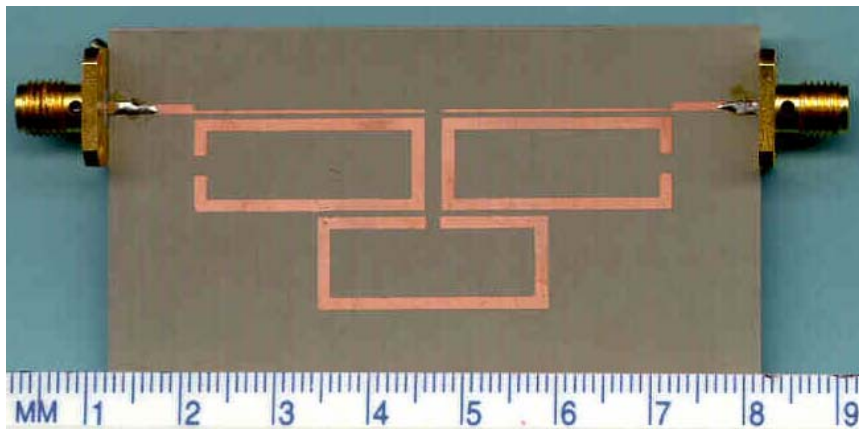

On RT/Duroid substrate with a relative dielectric constant of 10.8 and a thickness of 1.27mm

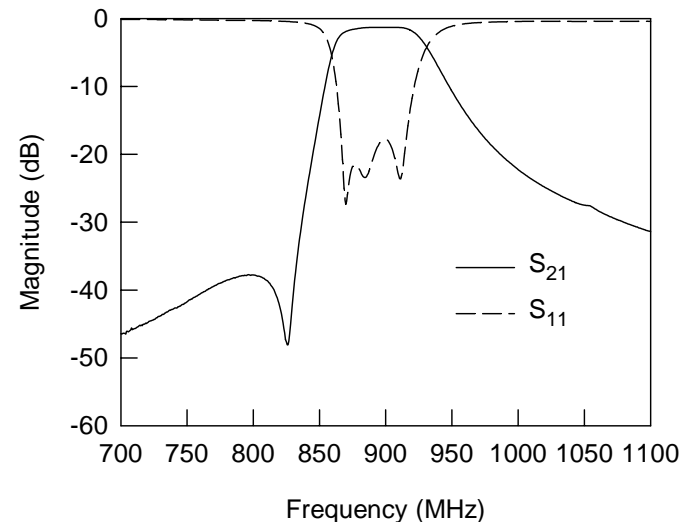

Measured response

Design Examples- Trisection open-loop filters

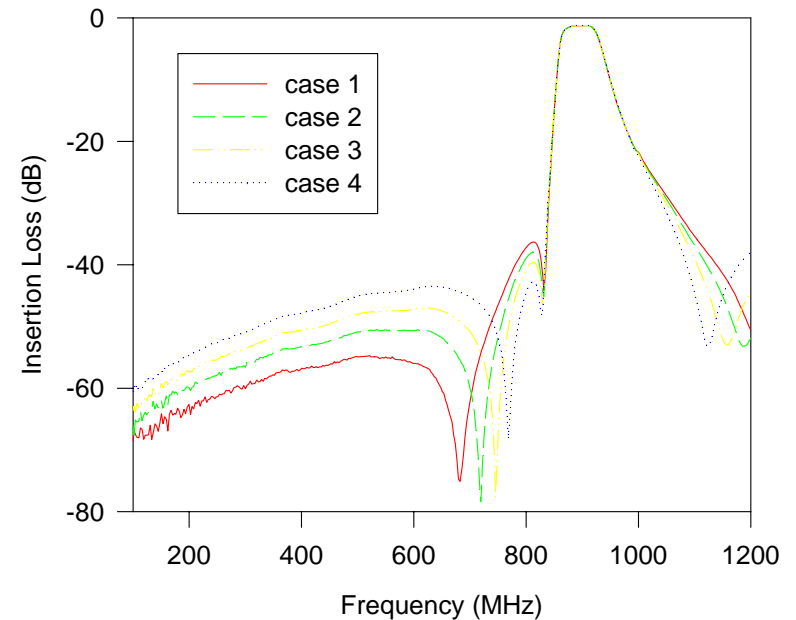
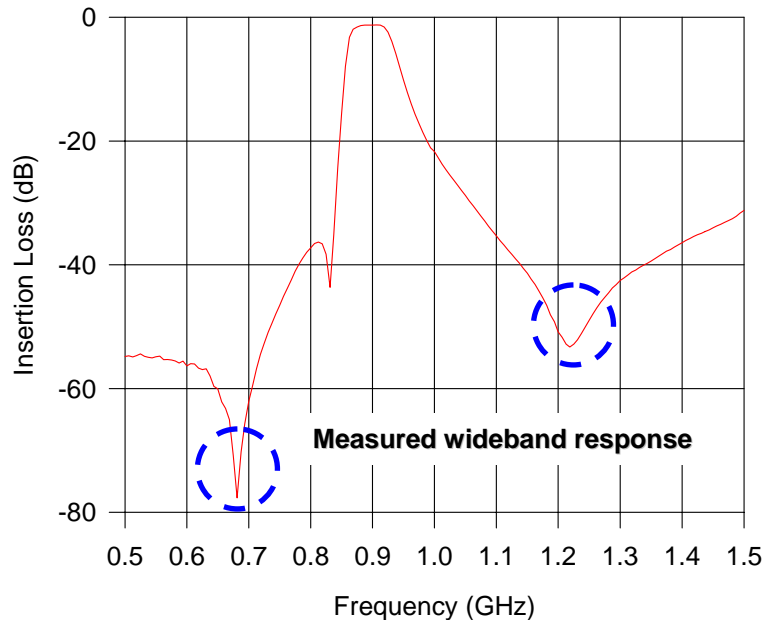
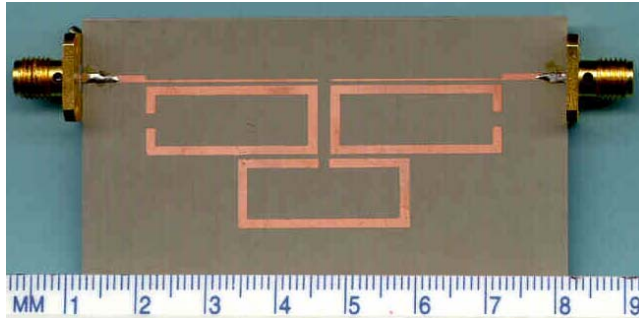

Experimental results on extra transmission zeros, where case 1 to 4 indicate the increase of direct coupling between the two feed lines.

Design Examples- Multi-layer filters

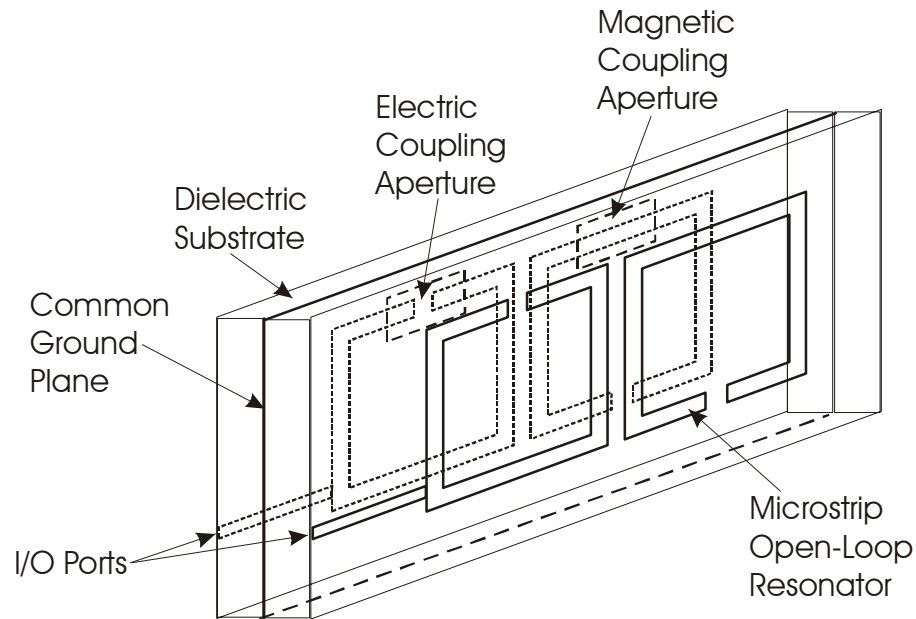

Design Examples- Multi-layer filters

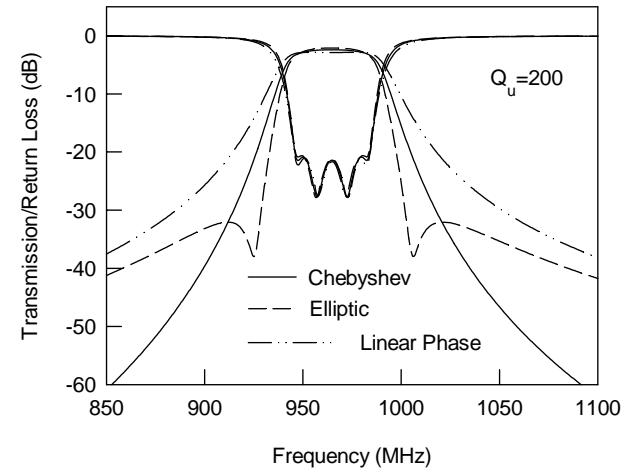
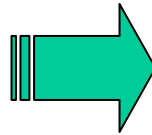
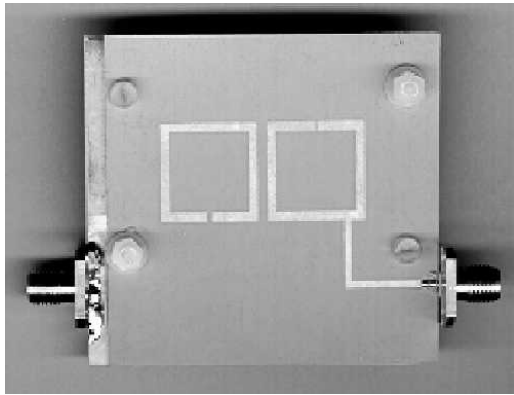

(a)

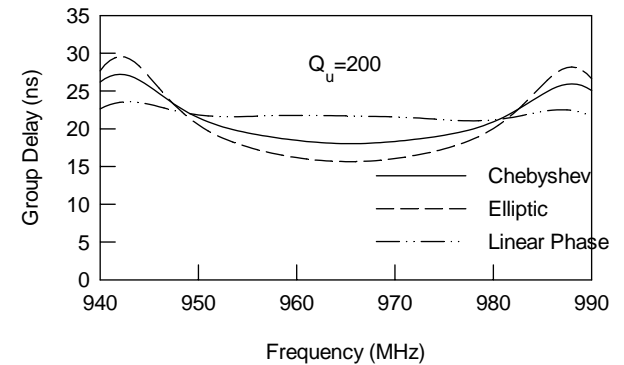

(b)

Design Examples- Multi-layer filters

Experimental results

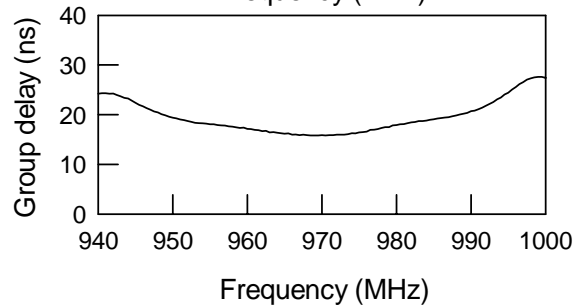
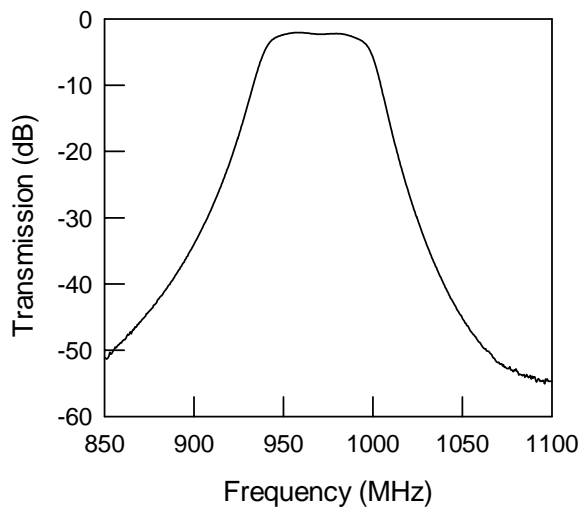

(a)

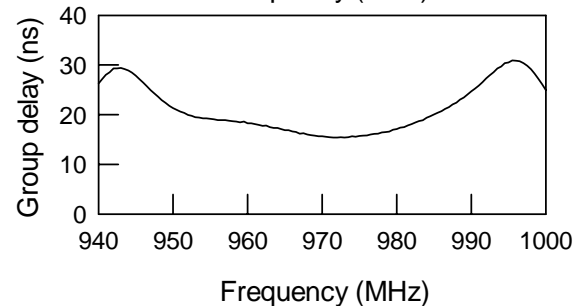
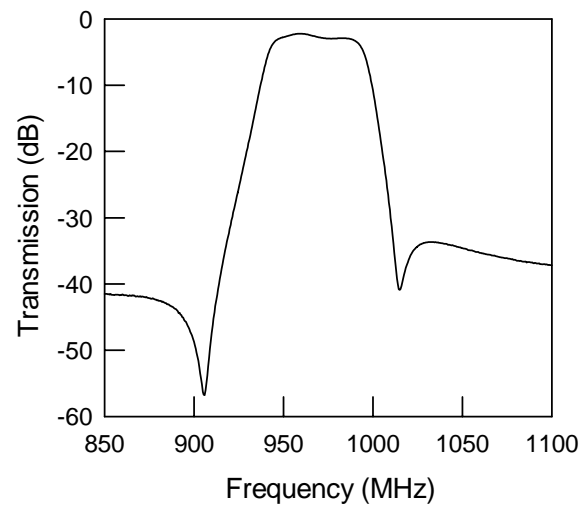

(b)

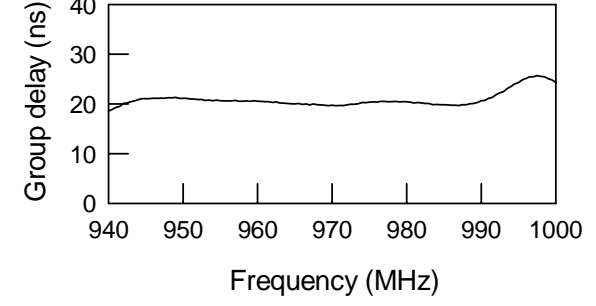
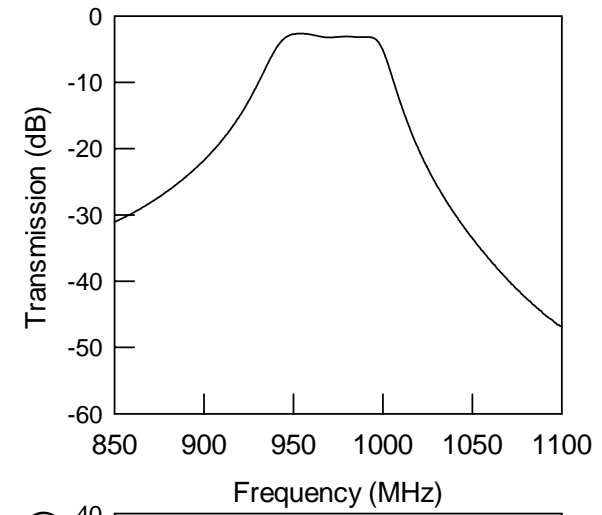

(c)

Design Examples- Slow-wave filters

Capacitively loaded line resonator

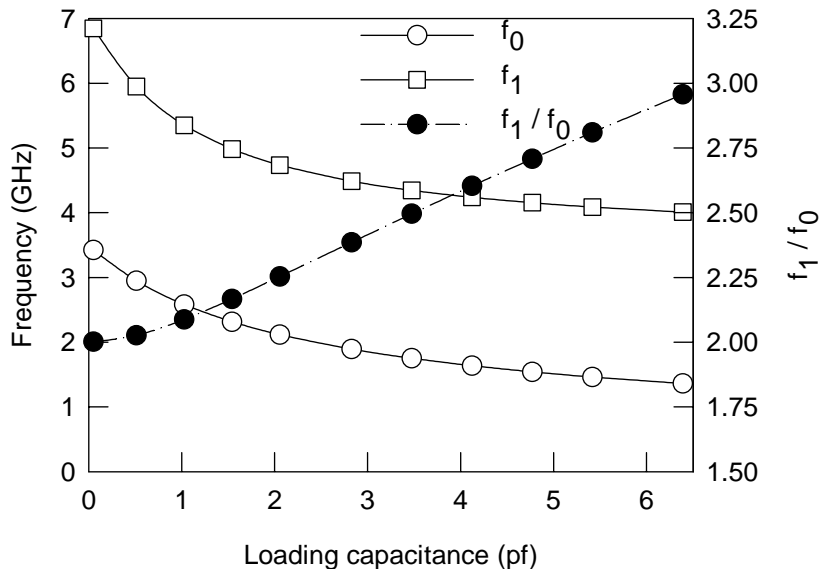
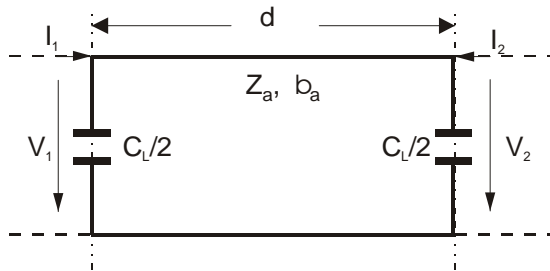

Microstrip slow wave resonator (I)

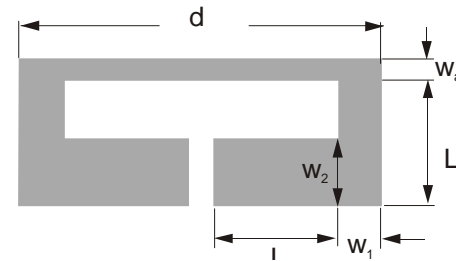

$W_a=1$ mm, $w_1=2$ mm,
 $w_2=3$ mm, $d=16$ mm
on RT/Duroid 6010

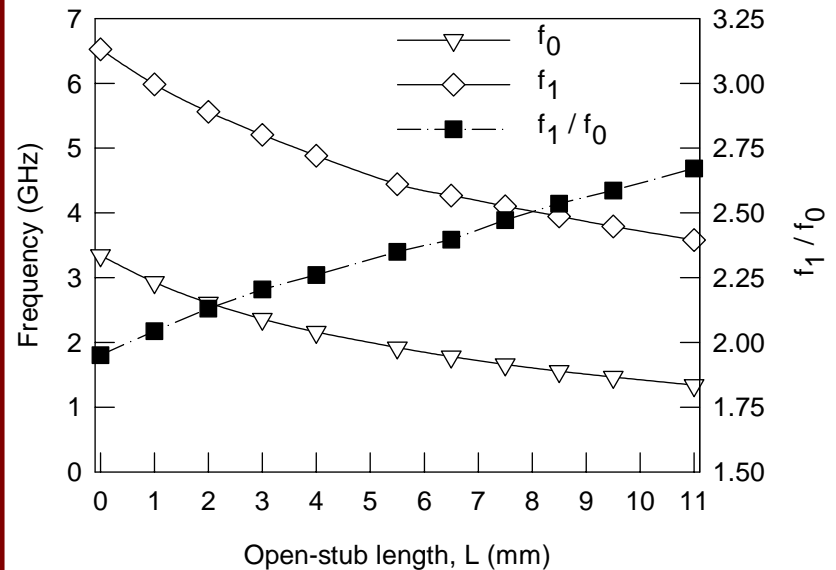

Design Examples- Slow-wave filters

Centre Frequency : 1335 MHz

3dB Bandwidth : 30 MHz

passband Loss : 3dB Max.

Min. stopband rejection :

D.C. to 1253 MHz 60dB

1457 to 2650 MHz 60dB

2650 to 3100 MHz 30dB

60dB Bandwidth : 200 MHz Max.

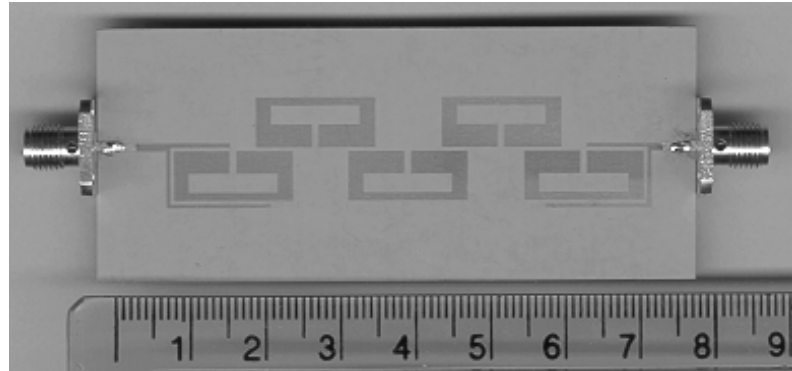

On RT/Duroid 6010 substrate

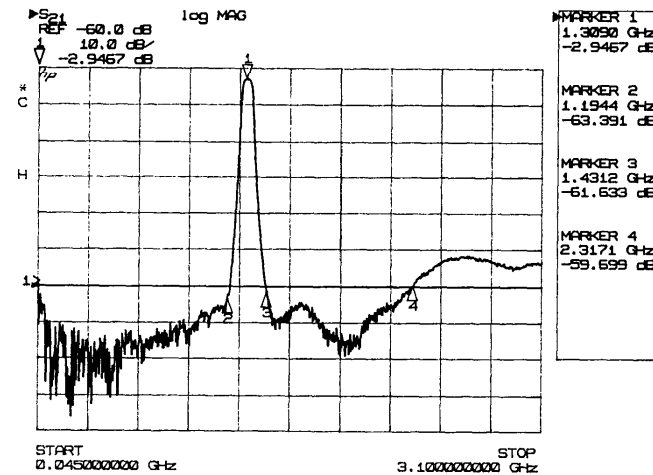
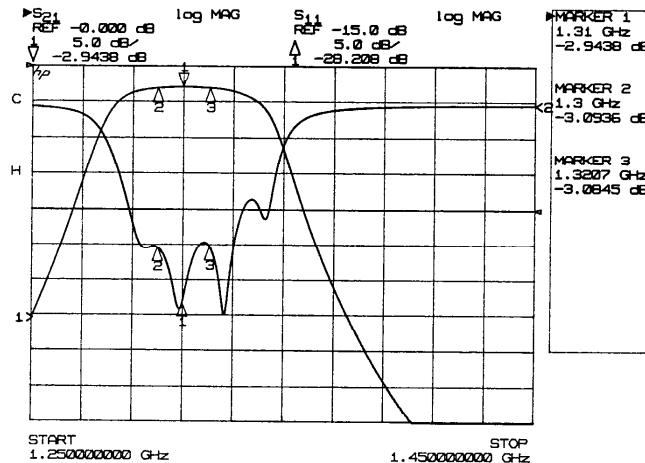

Design Examples- Slow-wave filters

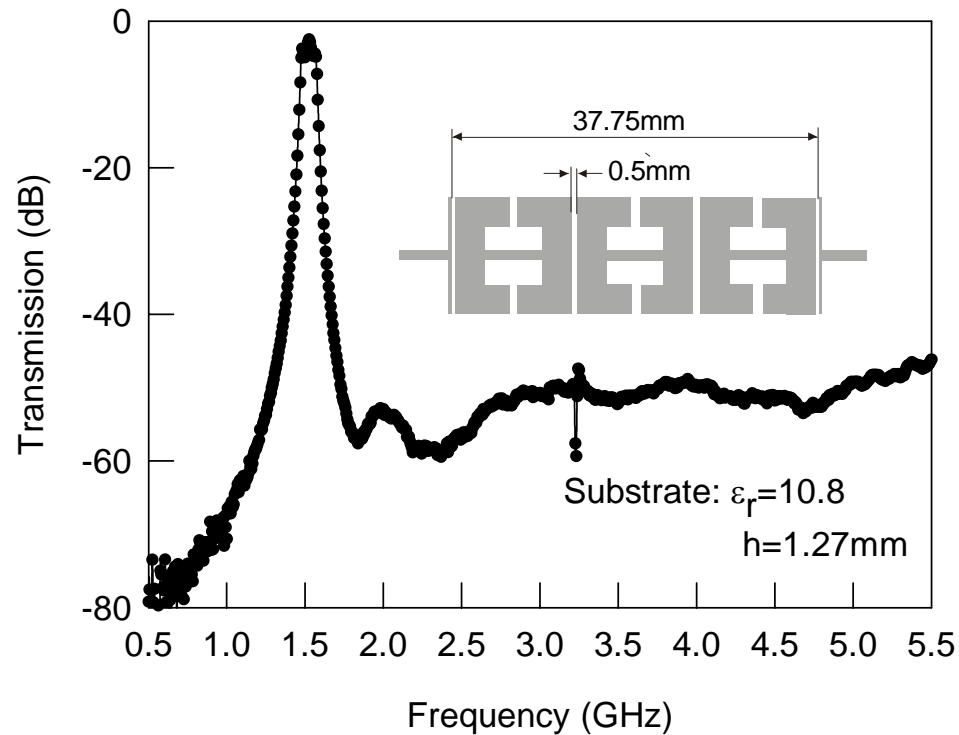

Design Examples- Dual-mode filters

Type I dual-mode resonator

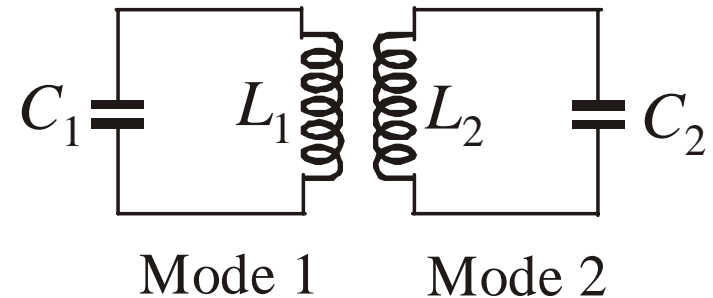
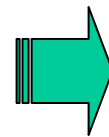
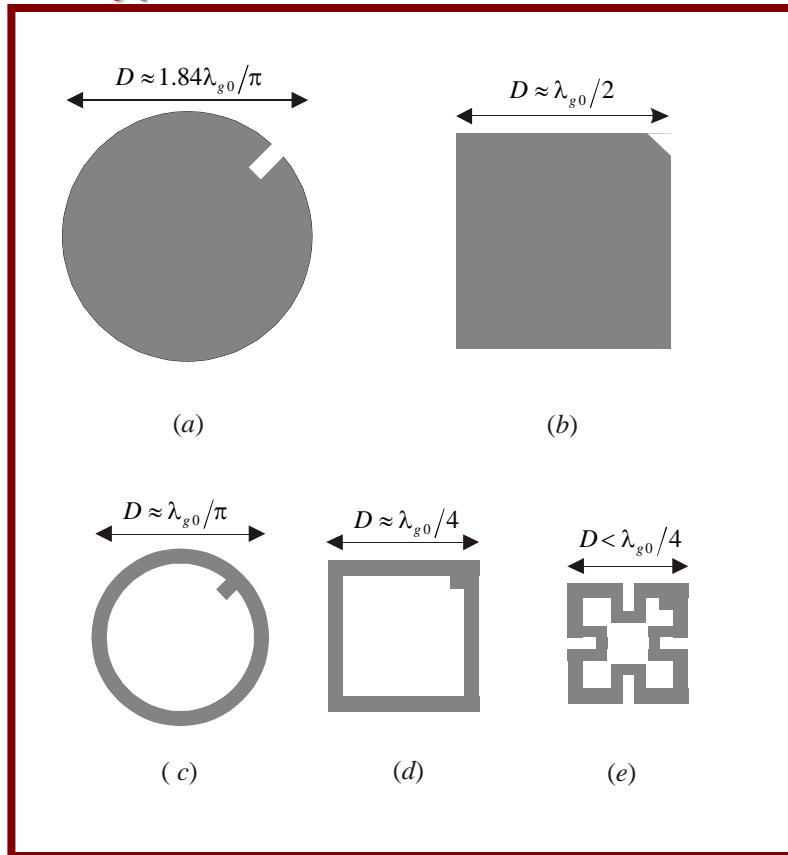

Design Examples- Dual-mode filters

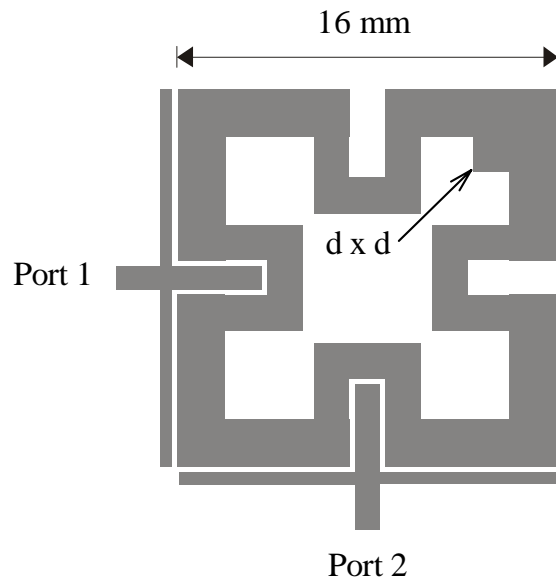

$d = 2$ mm on RT/Duroid
6010 substrate

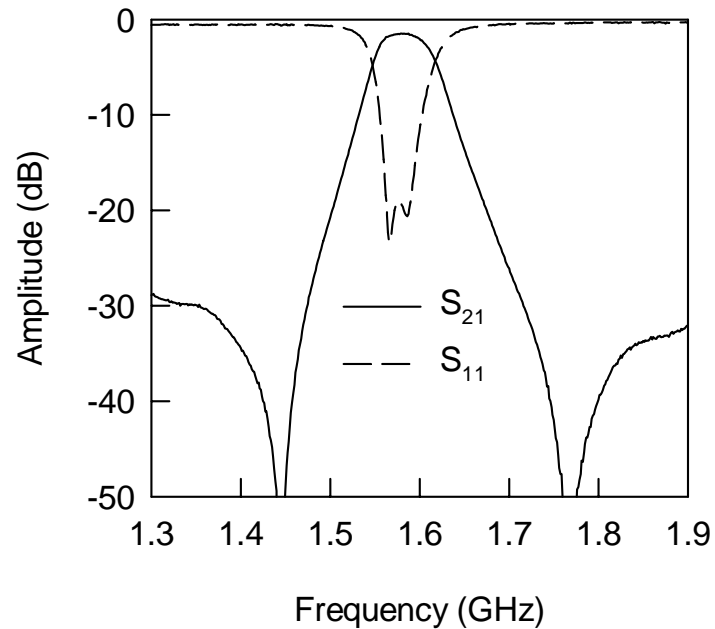

2.5% bandwidth at 1.58
GHz

Design Examples- Dual-mode filters

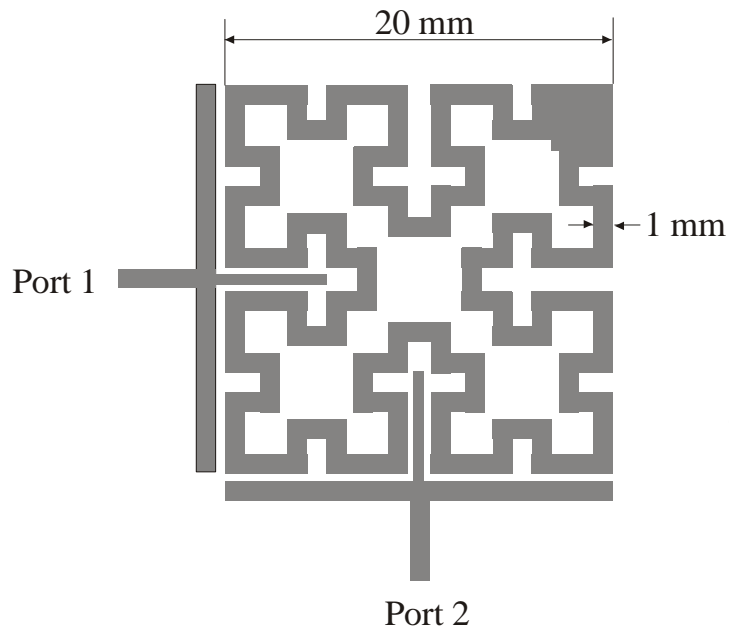

On RT/Duroid 6010 substrate

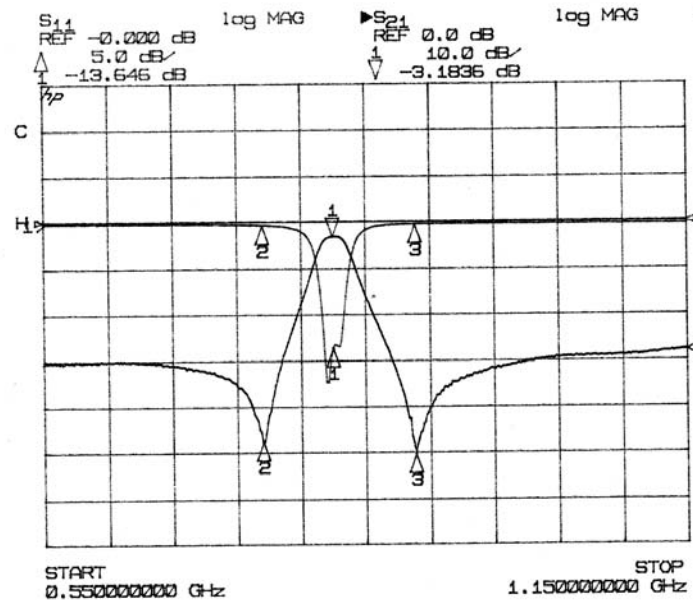

Centred at 820 MHz

Design Examples- Dual-mode filters

Type II dual-mode resonator

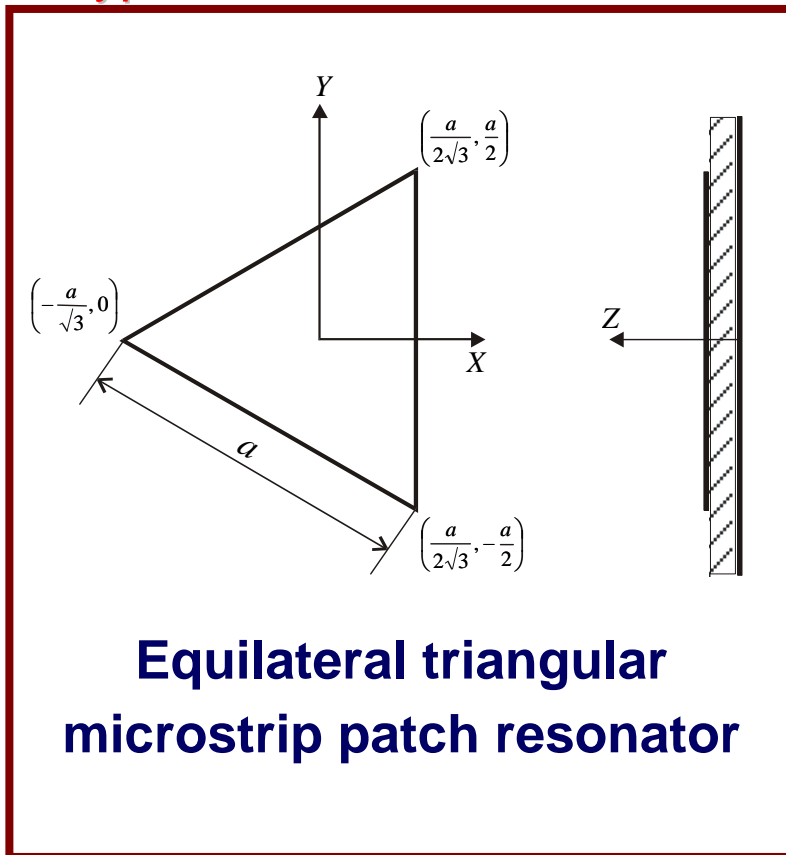

Electric Field Pattern

@ Mode 1

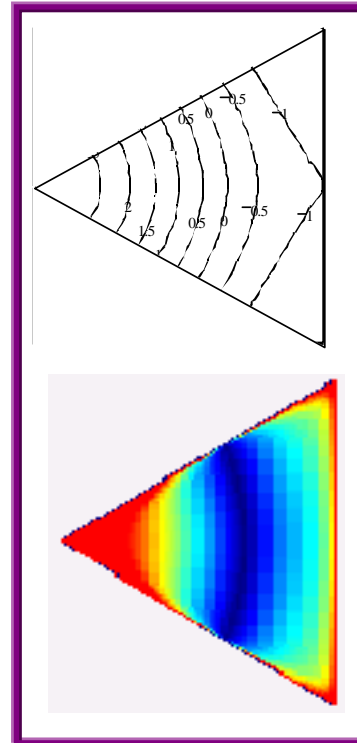

@ Mode 2

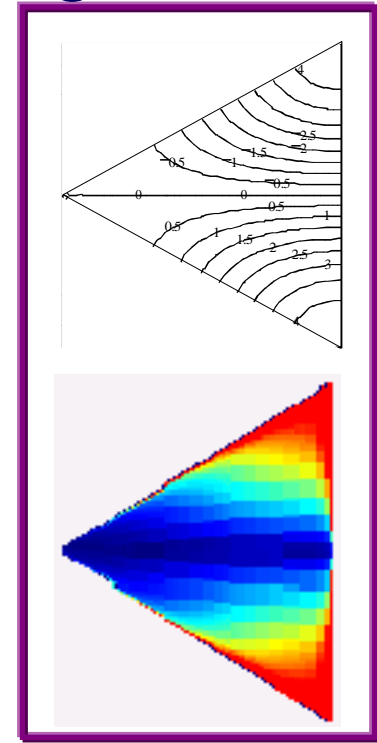

Design Examples- Dual-mode filters

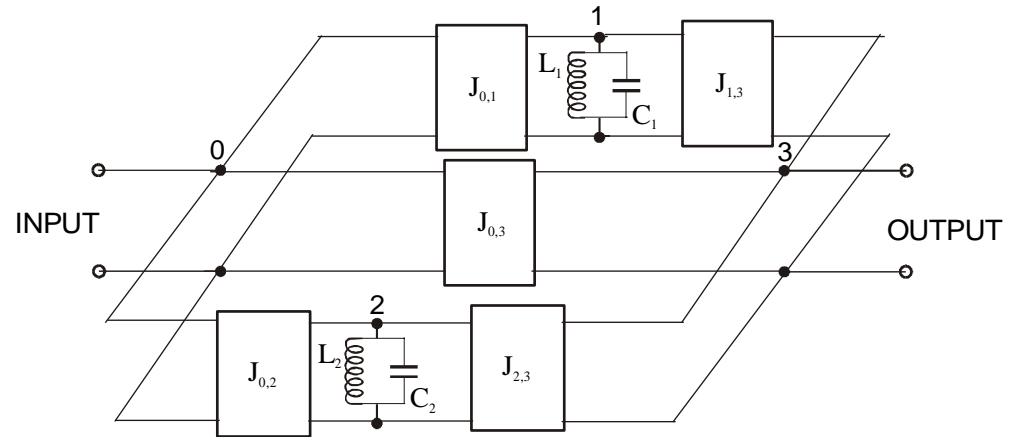
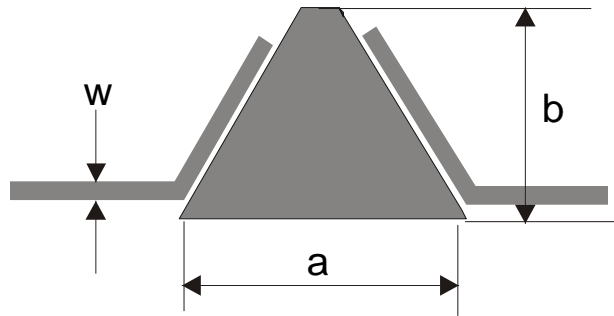

Circuit model (No coupling between the two modes)

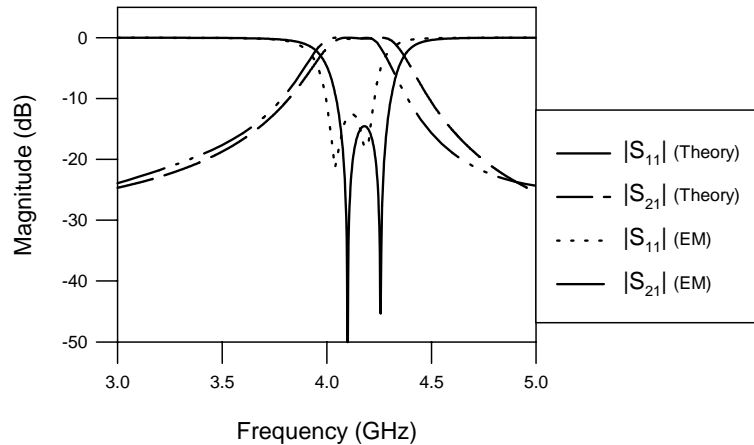

Frequency response

($a = 15$ mm and $b = 11.25$ mm on a 1.27mm thick dielectric substrate with a relative dielectric constant of 10.8)

Design Examples- Dual-mode filters

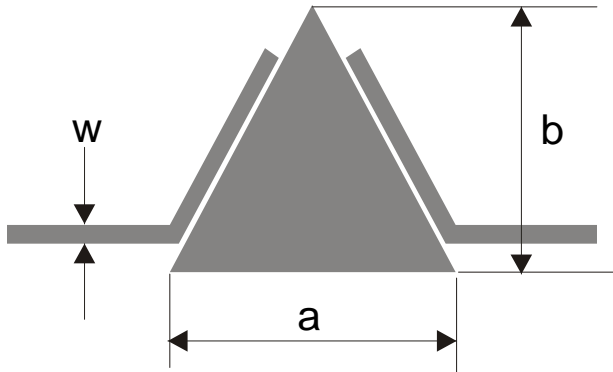

$a = 15$ mm and $b = 14$ mm
on a 1.27mm thick dielectric
substrate with a relative
dielectric constant of 10.8

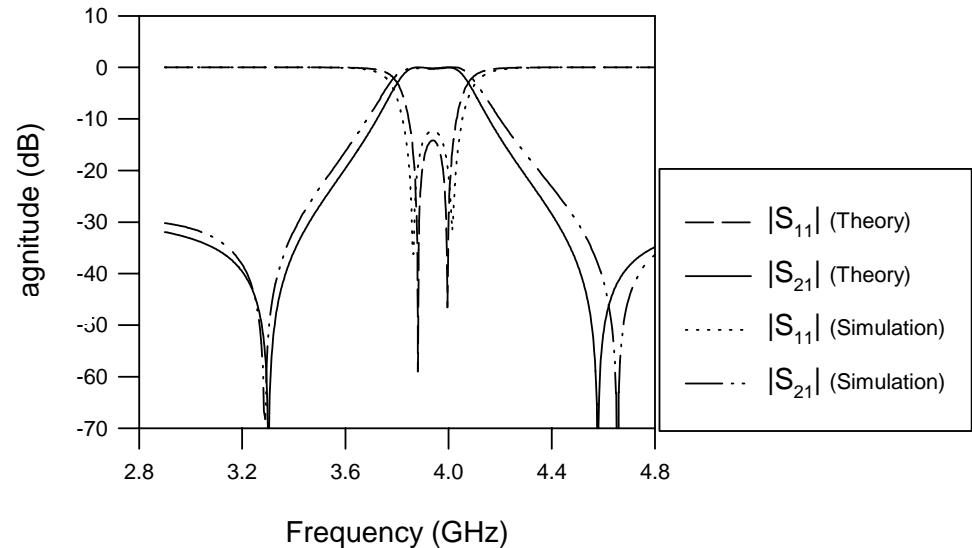

Frequency response

Design Examples- Dual-mode filters

Four-pole dual-mode filters

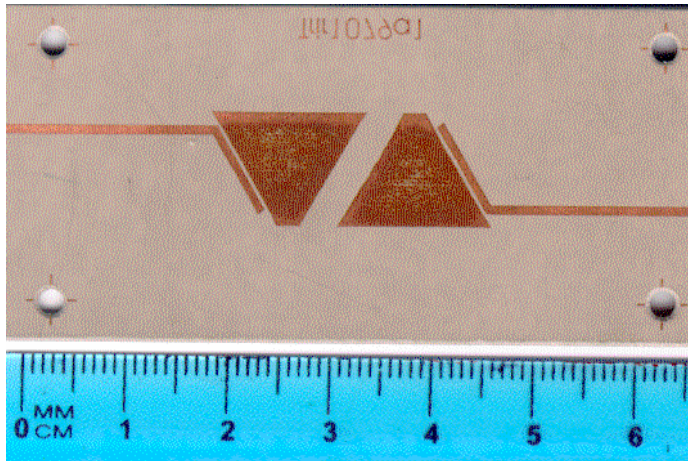

On a substrate with a relative constant of 10.8 and a thickness of 1.27 mm

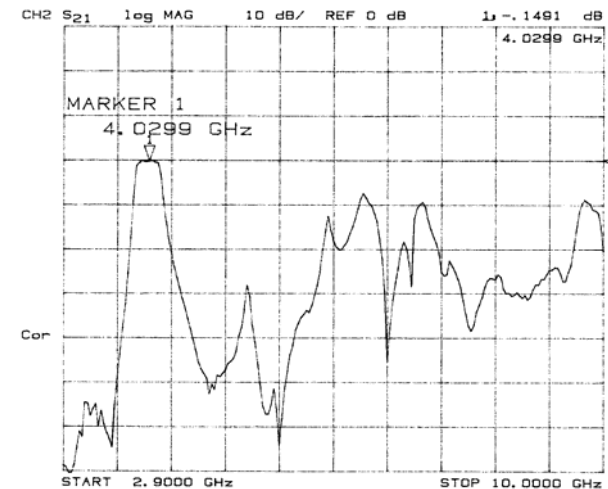
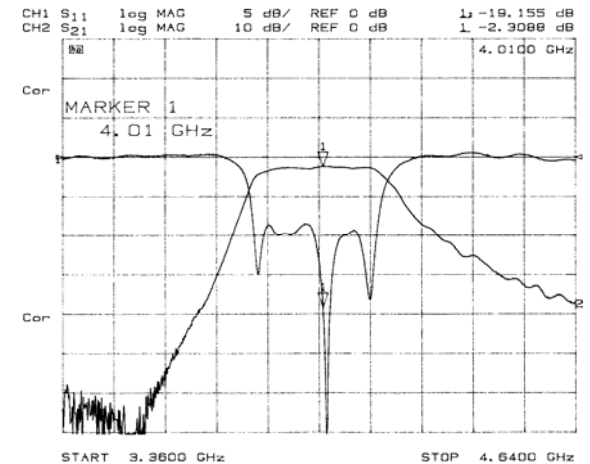

Design Examples- Dual-mode reject filters

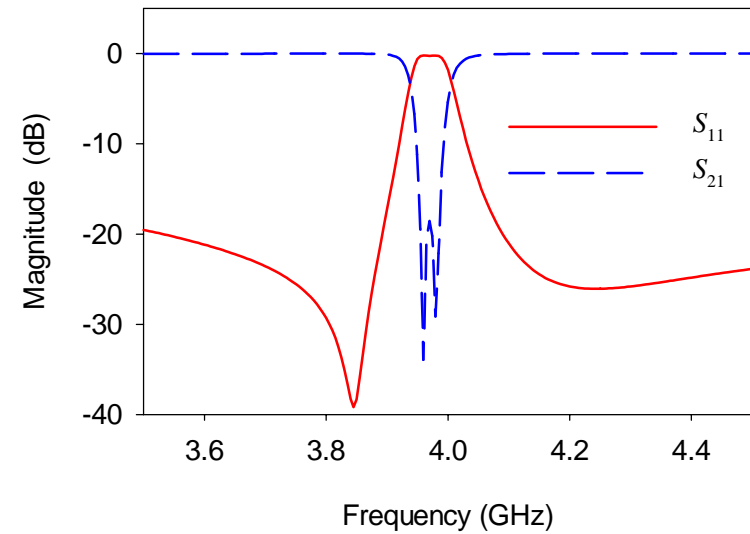
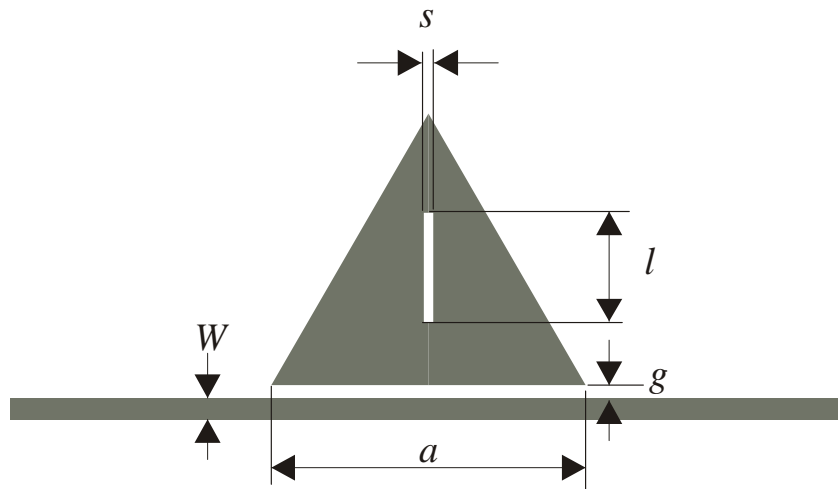

Single dual-mode resonator

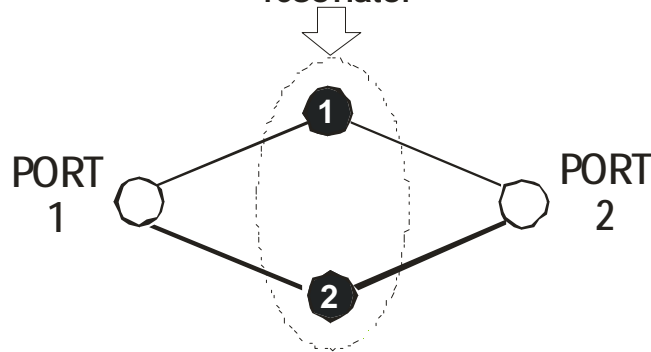

The details to be presented in another session (WE4C) at IMS2005

Design Examples- Extract-pole filters

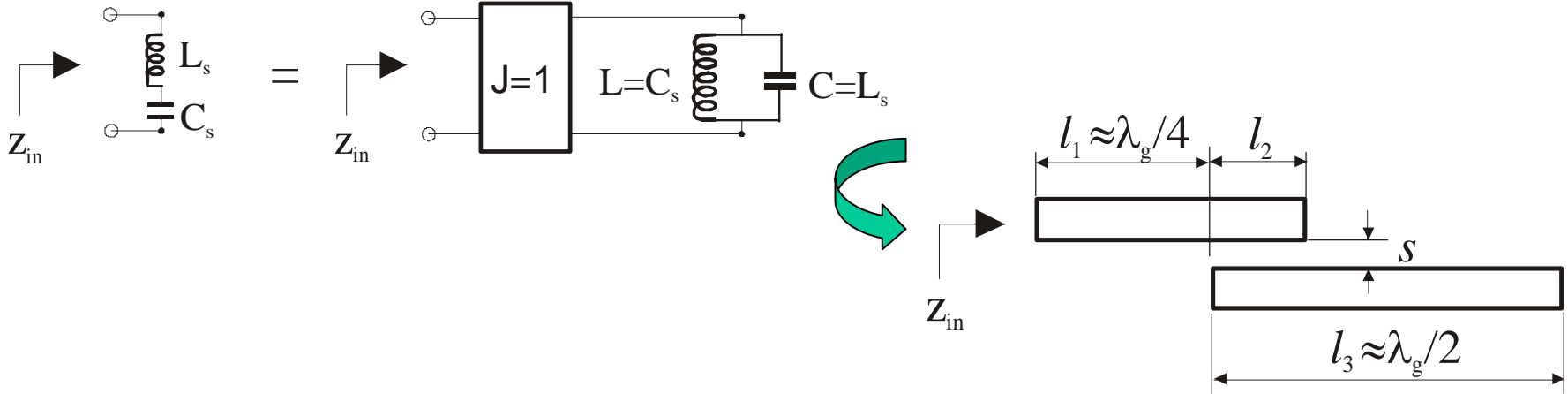
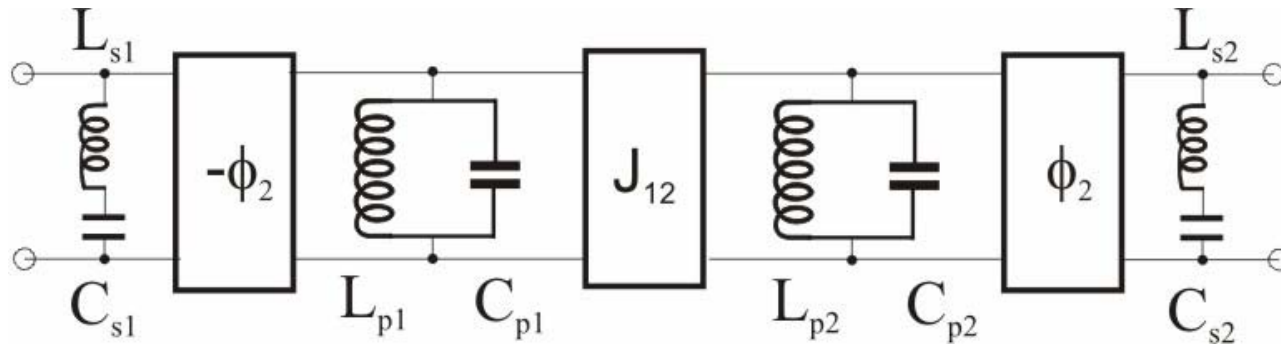

Design Examples- Extract-pole filters

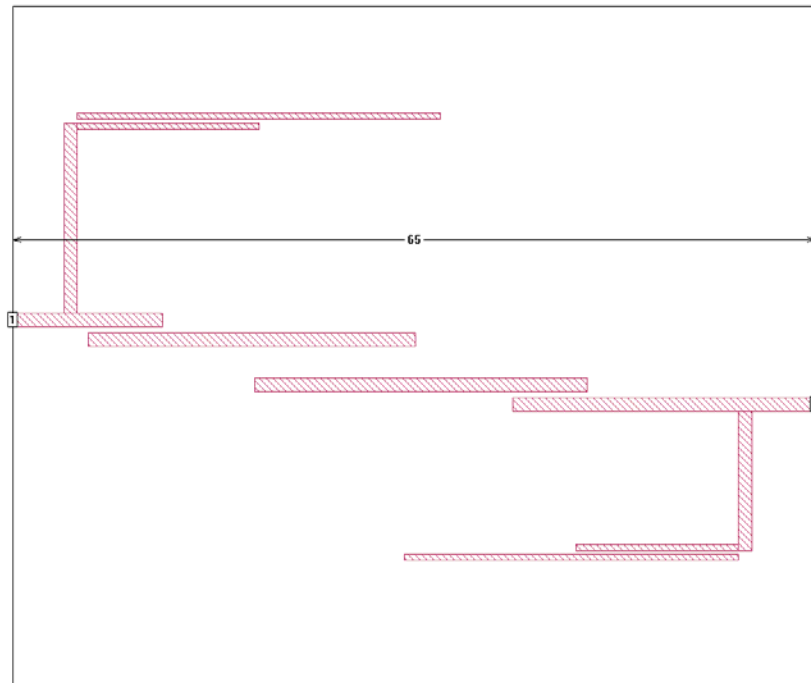

On RT/Duroid 6010 substrate

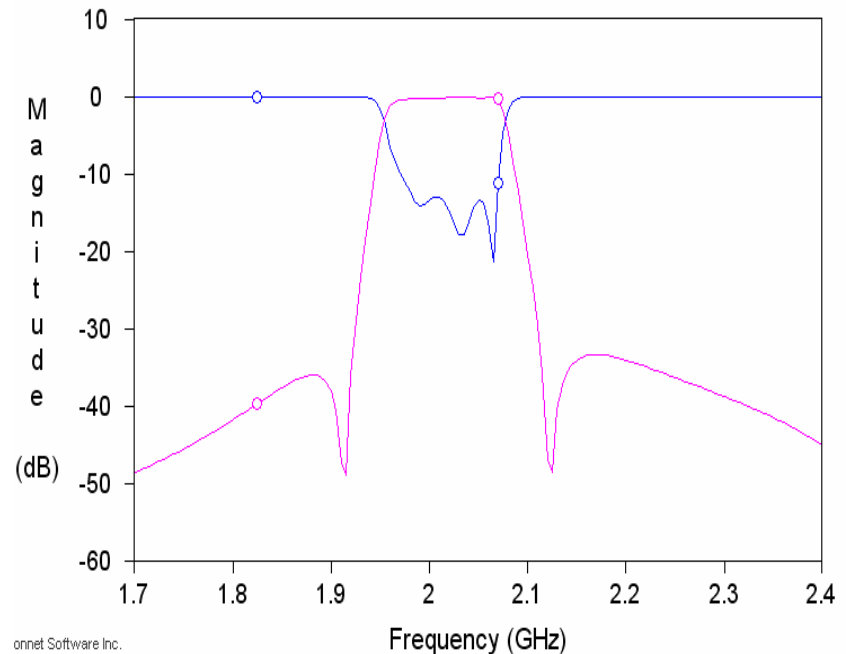

EM simulated performance

Design Examples- Extract-pole filters

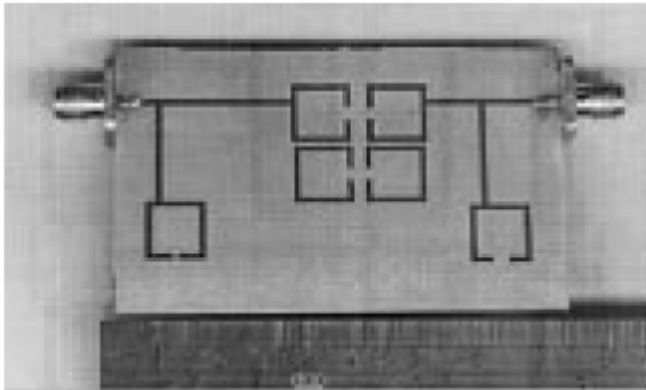
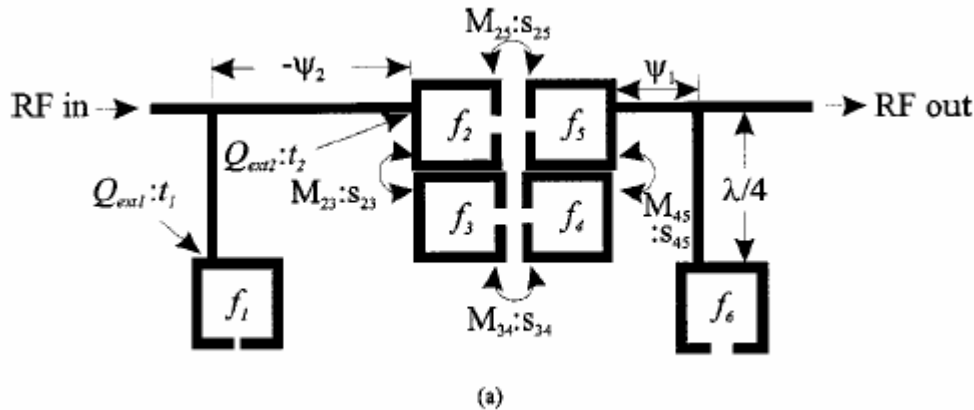

On RT/Duroid 6010 substrate

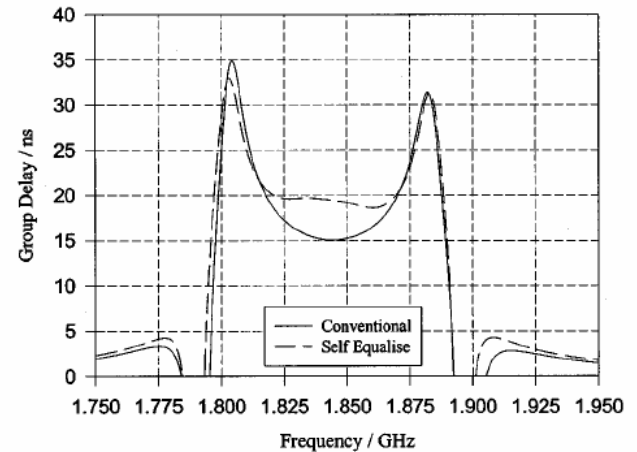
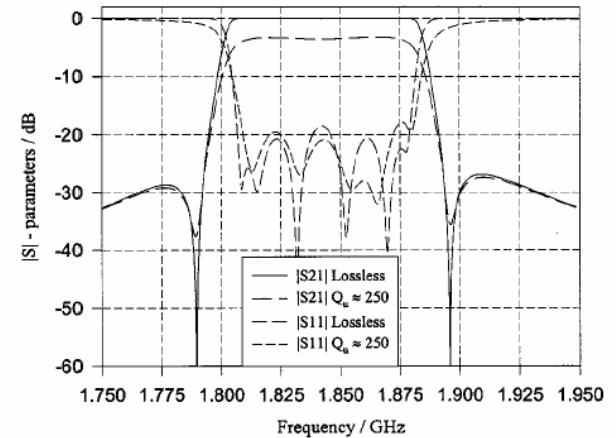

Design Examples- CQ filters

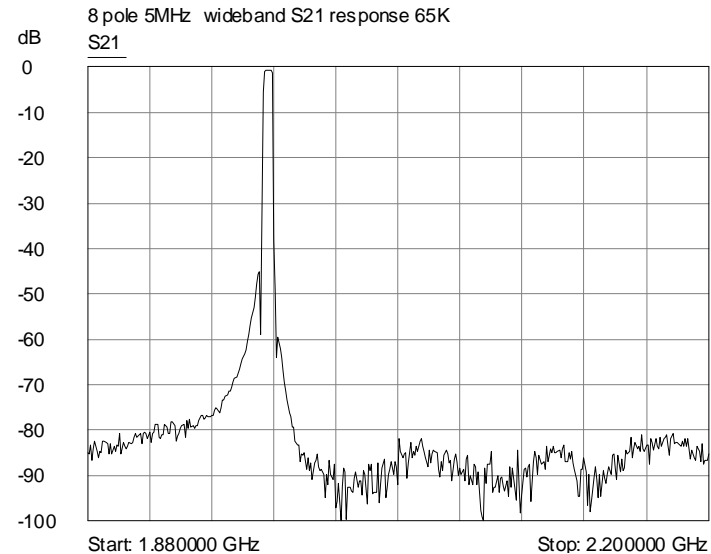
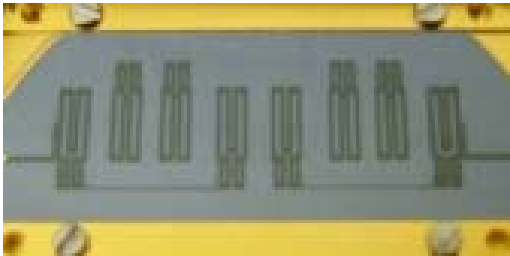
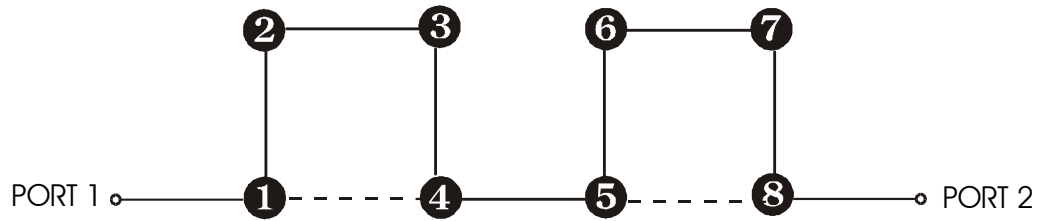

Another 18-pole filter of this type with group delay equalisation will be presented in TH1F session at IMS2005

Design Examples- CQT filters

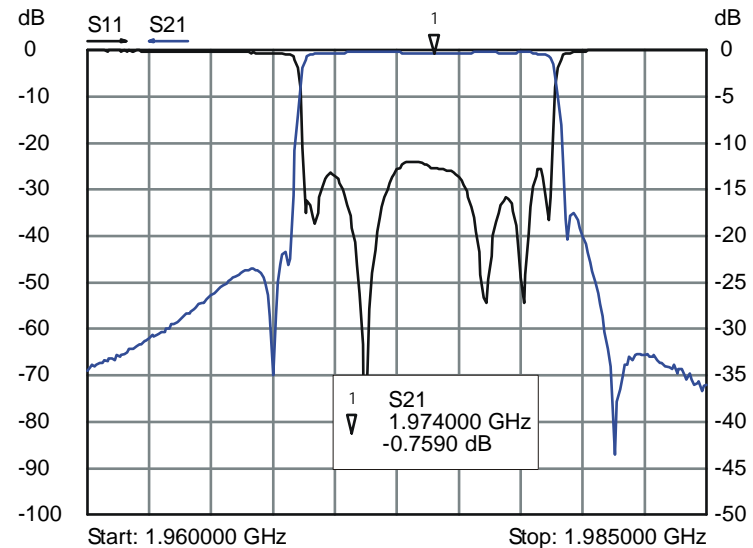
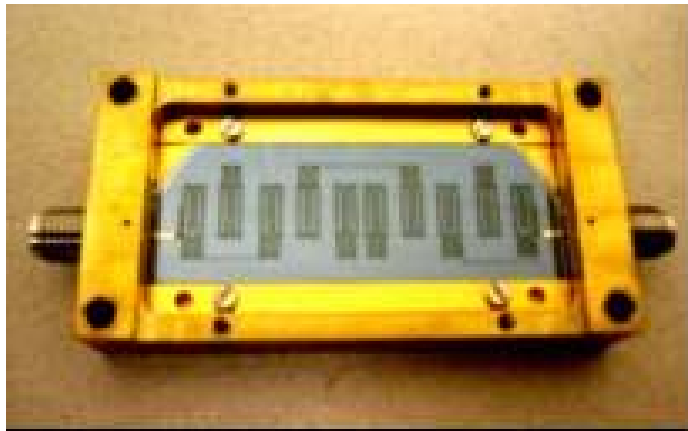
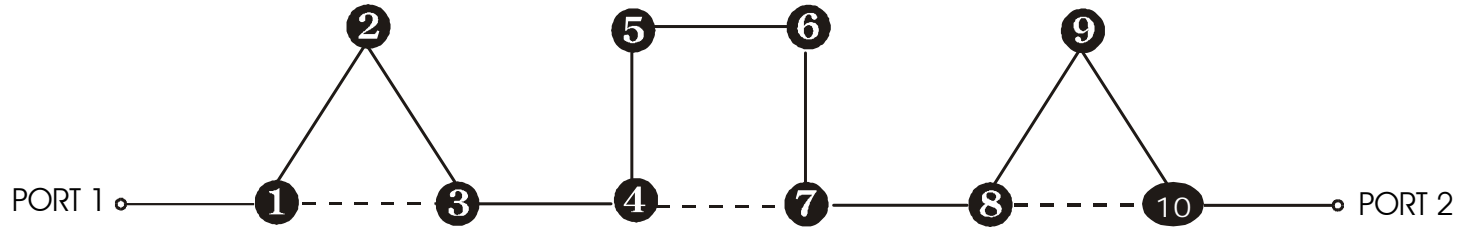

Design Examples- Wideband filters

Optimum stub bandpass or pseudo highpass

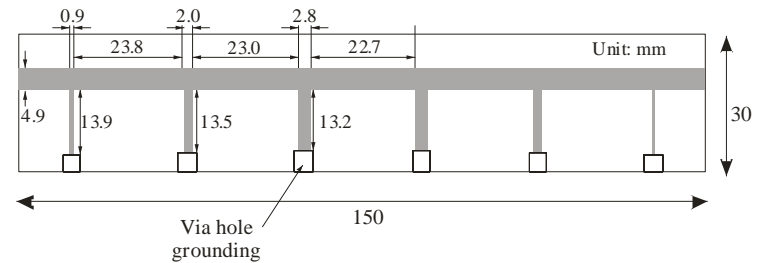
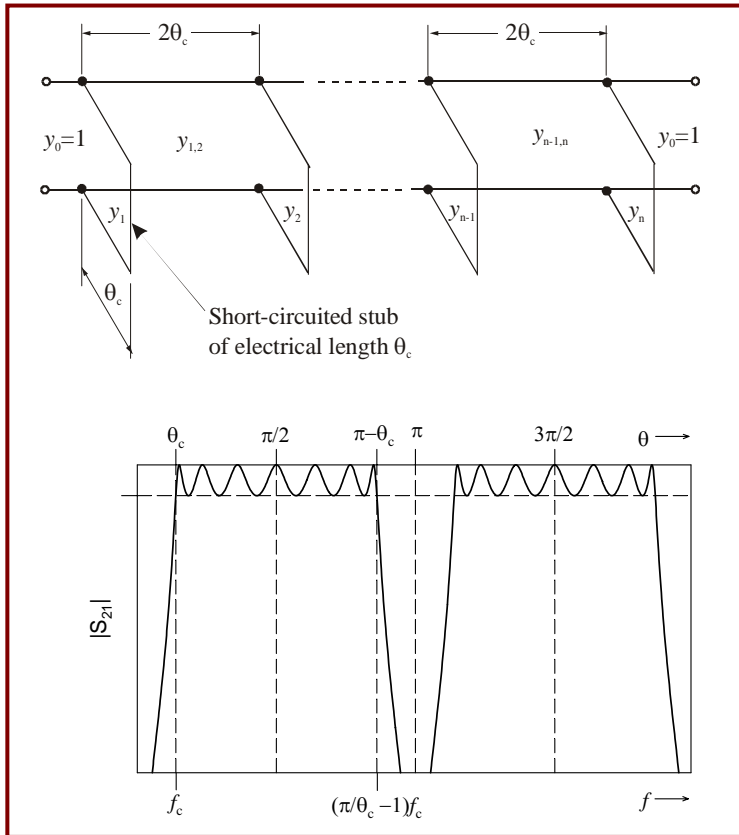

On substrate: $\epsilon_r = 2.2, h = 1.57$ mm

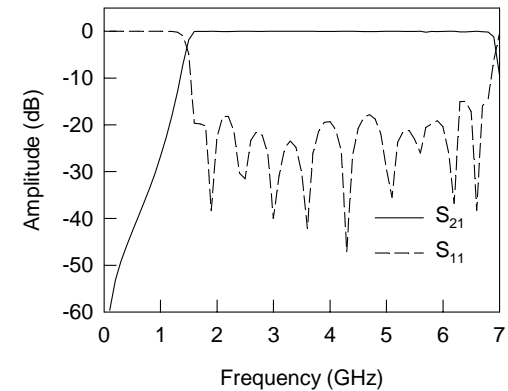

EM simulated performance

From: Jia-Sheng Hong and M.J.Lancaster, *Microstrip Filters for RF/Microwave Applications*,
John Wiley & Sons. Inc. New York, 2001

Summary

- ✓ Microstrip filter designs involve a number of considerations, including careful choice of topologies and substrates.
- ✓ Some design examples of new topologies with advanced filtering characteristics have been described, including –
 - Open-loop resonator filters
 - Multilayer filters
 - Slow-wave filters
 - Dual-mode filters
 - Extract pole, Trisection, CQ and CQT filters
 - Optimum wideband stub filters
- ✓ Driven by applications and emerging device technologies, many new and advanced microstrip filters have been developed and their designs are available in open literatures.